

Proudly made in the USA

Suspension MAXX

INSTALLATION INSTRUCTIONS

Part # SMX-10200 (2") , SMX-10230 (3")

For use with:

'94-'01 Dodge RAM 4x4 1500. '94-'13 RAM 4x4 2500 & 3500 inc. Mega Cab



Thank You for choosing SuspensionMAXX for your vehicle. This kit is designed to add suspension travel and increase front ground clearance. Specially designed tools and experience are required to complete the installation properly. These parts should only be installed by a Qualified Mechanic otherwise an unsafe vehicle and/ or personal injury may result. Consult manufacture's service manual for proper torque specifications and procedures. Instructions are supplied for the leveling kit installation only. Safety is most important. Use safe working habits.

Notice:

This product combines with the coil spring to increase suspension height either 2.0" or 3.0" (depending on part number) for a smoother ride. Enhances ride profile and is an economical alternative to expensive lift kits! This kit allows for up to 34" tires.

WARNING! This suspension system will enhance off road performance and increase ground clearance! Larger tires will increase vehicle roll center height. The vehicle will handle and respond to driver steering and braking differently from a stock factory equipped passenger car or truck. Extreme care must be used to prevent loss of control or vehicle rollover during abrupt maneuvers both on and off-road. Failure to operate this vehicle safely can result in vehicle damage, serious injury or death to the driver and passengers. Always wear your seat belts and reduce your speed, avoid sharp turns, inclines and abrupt maneuvers.

Tread lightly, respect nature and enjoy the Off-Road Experience!

Help keep it available for future generations.

Thank You! Suspension MAXX Inc.

Lift Your **Attitude!**
Retain your factory ride



Again, thank you for your purchase! Enjoy your SuspensionMAXX leveling system!

Questions? E-mail us at tech@suspensionmaxx.com or call 1.888.MAXX.CAM



Proudly made in the USA

Suspension MAXX

1

Tools required for installation:

1. Safety Glasses and Related Safety Equipment
2. Load rated safety stands, floor jack and wheel chocks
3. Metric/American socket set / wrench set / torque wrench (150 ft-lb)
4. Medium size pry bar/ Brass drift /Hammer

Installation procedure

1. Place vehicle on solid level surface set parking brake block rear wheels

2. Raise vehicle under frame and secure with load rated jack stands. Front axle completely unloaded of vehicle weight

3. Mark wheel lug location and remove front wheels

4. Mark coil springs (left & right) and coil end index location on axles. (Fig 1.4)

5. Mark lower cam adjuster location (both sides) if equipped for future reference (Fig 1.5)

6. Notice support front axle with load rated floor jack for the duration of disassembly & installation

7. Unbolt brake hose/line mounting bracket, allow slack clearance to lower axle (Disconnecting hydraulic brake flex hose from caliper or steel supply line NOT required)

8. Remove ABS wire retainer clamp from both sides.
Caution! Do not damage ABS cable or terminals

9. Remove upper or lower sway bar link attaching nuts on both sides. **Do not spin studs with air wrench.**
Damage to link may occur! (Fig 1.9)

(Fig 1.4)

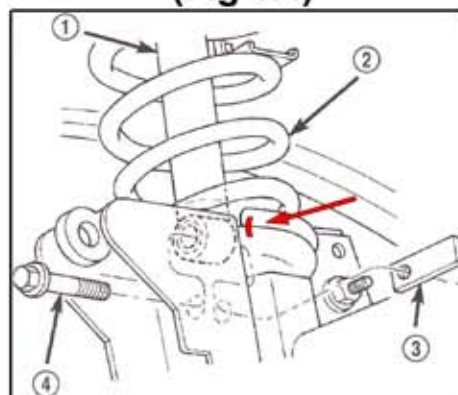

(Fig 1.5)

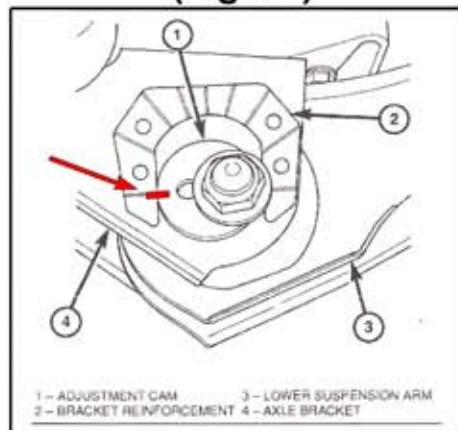

(Fig 1.9)

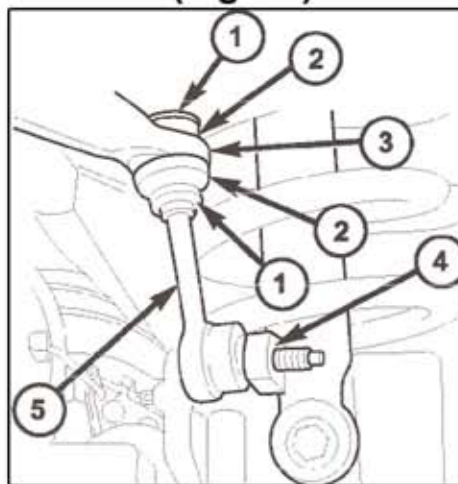

Again, thank you for your purchase! Enjoy your SuspensionMAXX leveling system!

Questions? E-mail us at tech@suspensionmaxx.com | or call 1.888.MAXX.CAM

Proudly made in the USA

Suspension MAXX

10. Remove lower shock absorber thru-bolt and nut. (Fig 2.10)

11. Remove 3 shock tower mounting nuts. Remove shock absorber through underhood (Fig 2.11)
(Removal of center shock nut and shock tower may be needed.)

NOTICE: Prevent shock shaft from turning, DO NOT spin with air wrench

12. Loosen/remove upper axle control links to allow axle freedom of movement (Loosen lower cam bolts if needed) (Fig 2.12)

13. Slowly lower axle to relaxed coil spring tension. Continue to lower front axle with load rated floor jack until springs clear upper frame mount

14. Remove upper coil rubber insulator. Remove 3 studded plate.

15. Install 1 MAXXSTAK RAM coil spacer per side. Thread nuts on to studs to hold spacer in place.

16. Reinstall coil springs as removed from vehicle, matching left and right sides, also aligning previous coil end index location. **NOTICE:** Reuse rubber coil insulator against MAXXSTAK Leveling Spacer.

17. Raise axle with floor jack

DANGER: Truck may lift from safety stands due to increased suspension height. USE CAUTION!

Fig 2.10

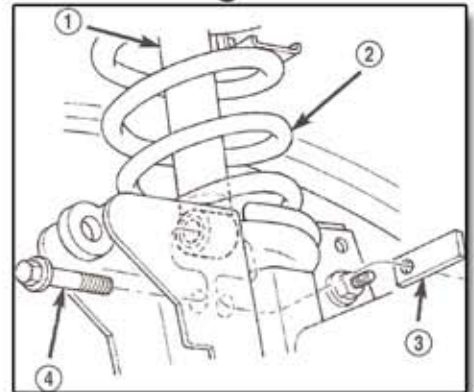

Fig 2.11

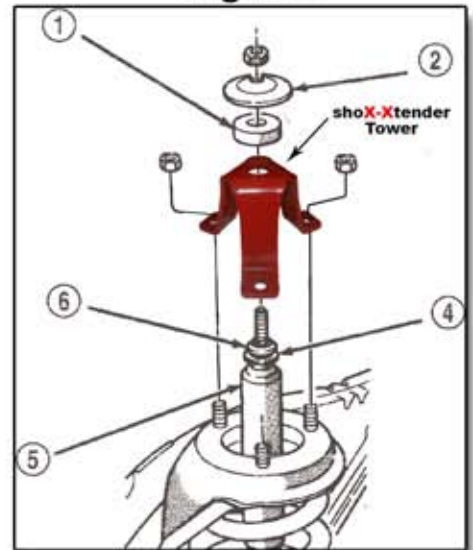
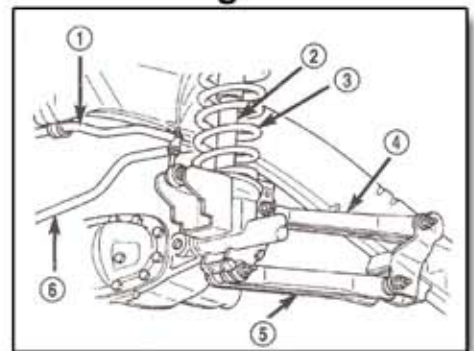

Fig 2.12



Again, thank you for your purchase! Enjoy your SuspensionMAXX leveling system!

Questions? E-mail us at tech@suspensionmaxx.com | or call 1.888.MAXX.CAM

FINAL REASSEMBLY

*Due to vehicle loads and spring options, longer shocks may be required

18. Reinstall shock absorber through underhood as removed. Reinstall shock tower, tighten 3 mounting nuts. **NOTICE: Prevent shock shaft from turning, DO NOT spin with air wrench**

19. Reinstall lower shock absorber thru-bolt and nut.

20. Reinstall/ tighten upper axle control links

21. Reset lower cam adjuster location (both sides) as marked in **Fig 1.5 (Step 5 on page 1)**

22. Reconnect sway bar links and torque fasteners

15. Reinstall brake hose brackets in original position

16. Reconnect ABS cables in reverse order

17. Reinstall front wheels in marked location, torque to manufacturer's specification

18. Check for tire / wheel clearance to critical suspension / steering / brake components (make adjustments as needed)

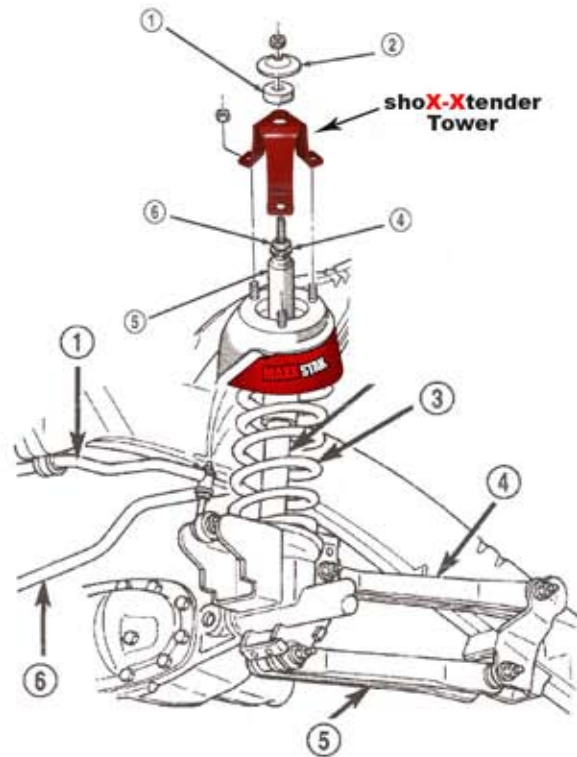

Fig. 1 Link/Coil Suspension

- 1 - STABILIZER BAR
- 2 - SHOCK ABSORBER
- 3 - COIL SPRING
- 4 - UPPER SUSPENSION ARM
- 5 - LOWER SUSPENSION ARM
- 6 - TRACK BAR

Wheel alignment recommendations

Camber = 0.0° + or - 0.7°

Caster = 2.7° + or - 1.0°

Total Toe = 1/8 Inch in



Again, thank you for your purchase! Enjoy your SuspensionMAXX leveling system!

Questions? E-mail us at tech@suspensionmaxx.com | or call 1.888.MAXX.CAM